

The Quantum Chess Story

SELIM G. AKL

*School of Computing and Department of Mathematics and Statistics,
Queen's University, Kingston, Ontario, Canada K7L 3N6
E-mail: akl@cs.queensu.ca*

Received: February 19, 2016. Accepted: February 19, 2016.

This is the story of how the game of Quantum Chess came about, how it was invented, how it was brought to life by a brilliant undergraduate student, how it gained a quick but fleeting fame, and how it came back to prominence with a little help from Hollywood.

Keywords: Artificial intelligence, chess, quantum chess, quantum physics, superposition, entanglement.

1 THE BEGINNING

In the fall of 2009, I was teaching a graduate course in the School of Computing at Queen's University. The subject of the course was *Natural Computing*. The idea was to study the processes of nature, such as photosynthesis for example, as computations, so that they may be better understood. At one of the lectures, the subject of artificial intelligence (AI) came up and an interesting discussion ensued. The class was made up of students with an eclectic set of backgrounds, including computer science, of course, but also biology, philosophy, mathematics, physics, and engineering. Students debated with passion and intelligence the respective merits of natural versus artificial intelligence.

At one point, when the exchanges started to become too animated, I volunteered the comment that a characteristic of AI is that the bar is constantly being raised, the target always moving upwards. Once a challenge is met, it is suddenly no longer AI, and a new challenge is formulated. Unaware of what I was getting into, I then added that when I was a graduate student,

AI's objective was to design a chess playing program that would demonstrate intelligence by playing at the top human level. This challenge was met, I stated, when the world chess champion Gary Kasparov was defeated by an IBM computer named Deep Blue, in a tournament organised by IBM in 1997.

Hoping to bring the discussion to an end, I concluded that the game of chess is no longer a challenge to AI. That is when things truly got out of hand. One of the students became extremely upset. He refused to accept that a machine can be better than a human. He said that the computer had won the match against Kasparov through sheer brute force. Also, in his opinion, IBM had rigged the tournament. He went on and on, there was no way to calm him down.

After class the student harangued me with emails. His ancestors, he claimed, had invented the game. My statements were an insult to them. Not willing to continue with this exchange, I offered the following response: Let us assume that there are 5 people today (among the 7 billion humans) who can beat the best chess playing program. How many will there be in 5 years? How many in 10 years? Eventually the number will be 0; it is only a matter of time.

2 ROCK, PAPER, SCISSORS

The following week I left home to attend a conference in Slovakia. On the plane, I kept reflecting on the incident in my class. One thought led to another and I wondered whether one could come up with a way to create a level playing field in computer programs that play games of strategy. In other words, can a match be found to the awesome power of computers? I could not think of a way, and so I turned to other distractions on the long flight.

The conference was held in the elegant Smolenice Castle flanked by deep forests on one side and farmers' fields on the other, a quiet and peaceful setting conducive to reflection. At one of the breaks, I mentioned the computer chess argument to my colleagues. "Forget it," one of them exclaimed, in his delightful and easily recognizable European accent, "Chess is solved; you should program the computer to play *rock, paper, and scissors*, now that would be a real challenge!"

On the flight home I pondered my colleague's suggestion. Surely, I had no idea how to make a computer play *rock, paper, and scissors* in an intelligent way. But there was something else I knew: quantum computing! Might the uncertainty inherent in quantum physics bring human and computer on an equal footing? There was something else I knew well: chess. So was born *Quantum Chess*, eleven kilometers above the Atlantic Ocean, in late October 2009.

3 QUANTUM CHESS ANYONE?

Why Quantum Chess? Conventional chess is a game of complete information, and thanks to their raw power and clever algorithms, computers reign supreme when pitted against human players. The idea behind Quantum Chess is to bring unpredictability into chess, and consequently place the computer and the human on a more equal footing, as they will both face the same unknown.

My paper on Quantum Chess first appeared on February 16, 2010 as a technical report [1] under the title *On the importance of being quantum*. It was later published in *Parallel Processing Letters* [2]. The paper described how Quantum Chess uses the weird properties of quantum physics, such as *superposition* and *entanglement*, to introduce an element of uncertainty into the game, thereby giving humans an equal chance when playing computers. Several variants of the game were proposed in the paper.

One variant uses quantum superposition. Unlike the chess pieces of the classical game, where a pawn is a pawn, and a bishop is a bishop, a Quantum Chess piece in this variant is a superposition of *states*, each state representing a different classical chess piece. Here, a player does not know the identity of a chess piece (that is, whether it is a pawn, a rook, a bishop, and so on) until the piece is selected for a move. Once a piece is selected it elects probabilistically to behave as one of its superposed classical pieces. Specifically, the act of touching a Quantum Chess piece (in order to make a move) is equivalent to a *measurement* (also known as an *observation*) in quantum physics. A measurement, according to the accepted theory, causes a quantum superposition to *lose its coherence*, meaning that it collapses into one of its constituent classical states with a certain probability. Thus, for example, suppose that a Quantum Chess piece is a superposition of the left knight N_l and the right rook R_r , then this is denoted as:

$$|\psi\rangle = \alpha|N_l\rangle + \beta|R_r\rangle,$$

where α and β are complex numbers, such that $|\alpha|^2 + |\beta|^2 = 1$. When the piece $|\psi\rangle$ is touched by a player, this defines the player's move: the piece moves as N_l with probability $|\alpha|^2$ and as R_r with probability $|\beta|^2$. Soon thereafter, however, Quantum Chess allows a classical piece to recover its quantum state and return to being a superposition of two or more pieces, depending on whether it lands on a white square, where it remains classical, or on a black square, where it traverses a *quantum circuit* that restores its superposition. The quantum circuit in each black square consists of *quantum gates*, such as *Hadamard gates* and *Controlled NOT* gates. An example of such a circuit is shown in Figure 1.

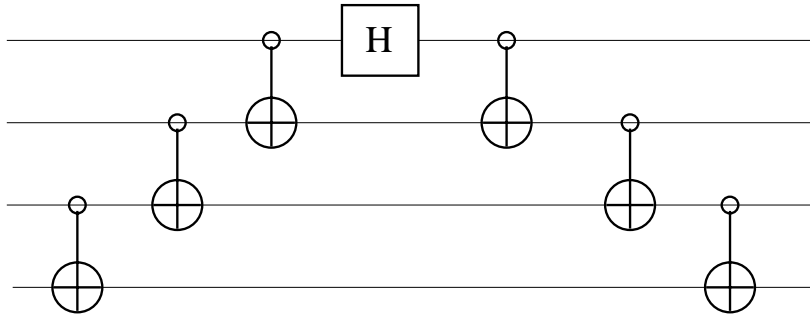

FIGURE 1
Quantum circuit for black squares on chess board.

Suppose that each classical chess piece is represented using four bits (a fifth bit may be used to determine whether the piece is black or white). The circuit of Figure 1 has four input lines, four output lines, one Hadamard gate, and six Controlled NOT gates. The circuit is capable of transforming a classical number from 0 to 15 into a quantum superposition of two states (and vice versa) [2].

Another variant of Quantum Chess uses quantum entanglement. Thanks to this bizarre property of quantum physics, the state of a chess piece is somehow ‘bound’ to the state of another piece, regardless of how far they are separated; touch one and you affect the other. The two entangled pieces can belong to the same player, or to different players. Multiple entanglements may also be allowed.

As well, the paper proposed different rules for playing Quantum Chess, suggesting an endless realm of possibilities. It examined what would happen if the computer playing Quantum Chess is itself quantum, and concluded with a number of philosophical considerations [2].

4 BRINGING QUANTUM CHESS TO LIFE

On December 2, 2009, Alice Wismath an undergraduate psychology student at Queen’s, walked into my office. She had just completed a couple of computing courses and was taken by the beauty of the field, the logic of algorithms, the precision of programming, and the amazing creative power that computers provide. She wanted to switch to computer science. A few months later the switch had taken place, and now Alice was looking for a summer project. I suggested that she take a look at my Quantum Chess paper. Because a true Quantum Chess board and true Quantum Chess pieces may be a few

years in the future, her project was to create a program that models one variation of Quantum Chess, as well as a computer strategy to play the game.

Alice did so splendidly. Near the end of the summer of 2010, she had a working software version of Quantum Chess that simulated the quantum properties and implemented a set of rules selected from a myriad of options [5]. The rules in Alice's implementation are summarized in what follows.

4.1 Pieces

1. Each Player has sixteen pieces.
2. Pieces are in a quantum superposition of two piece-type states: a primary type and a secondary type.
3. Pieces can be in either quantum (unknown) state or classical (known) state.
4. When a piece collapses to classical state, it becomes one of its two piece types with equal probability.
5. The king is an exception: it is permanently in classical state.
6. At any time during the game, each player has exactly one king on the board, and its position is always known.
7. The remaining fifteen pieces are assigned the following primary piece types: left rook, left bishop, left knight, queen, right knight, right bishop, right rook, and pawns one through eight.
8. Secondary types are then randomly assigned from this same list of piece types, so that each type occurs exactly twice in the player's pieces.
9. Pieces are created at game start up, and the superpositions do not change throughout the game.
10. Each player's pieces are initially positioned as in traditional chess, on the first two rows, according to their primary piece type, with all the pieces, except for the king, in quantum state.
11. When a piece in quantum state is touched (that is, chosen to move) it collapses to one of its two piece-type states, and this type is revealed to both players.

4.2 Board

1. The board consists of the usual 64 squares of alternating black and white.
2. When a piece lands on a white square, it remains in its classical state.
3. When a piece (excepting the king) lands on a black square, it undergoes a quantum transformation and regains its quantum superposition.

4.3 Play

1. The player whose turn it is to move, chooses a piece and touches it.
2. Once a piece has been touched, the player must move that piece if it has any possible moves.
3. If a quantum piece collapses into a piece type with no possible moves, then the player's turn is over.
4. Pieces in classical state with no possible moves may not be chosen.
5. The pieces move as in classical chess, with the following exceptions:
 - (a) Castling is not allowed.
 - (b) The *en passant* rule for pawn capturing is left out.
 - (c) The king may be placed, or left, in check.
6. Pieces capture normally.
7. When a quantum piece is captured it collapses before it is removed from the game.
8. Captured pieces may be seen in the panels at the sides of the board.
9. If a player touches a quantum piece which collapses to a piece state in which it puts the opponent's king in check, this counts as their move, and it becomes the opponent's turn. (However it is not enforced that the opponent must then get out of check).
10. A pawn reaching the opposite side of the board may be promoted to a queen, bishop, rook, or knight, regardless of the number of pieces of that type already in the game.
11. If a piece in quantum state on the far row is touched and revealed to be a pawn, it is promoted, but the promotion takes up the turn. The superposed piece type is not affected.

4.4 Ending the game

1. A player wins when they capture the opponent's king. (Unlike in traditional chess, checkmate is not detected, and the king may be moved into check.)
2. The game is designated a draw if both players have only the king remaining, or if 100 consecutive moves have been made with no captures or pawn movements by either side.

4.5 Two versions

In fact, Alice had two versions: one version for two humans to play one another, and another for a human to play a computer. In the latter case, Alice

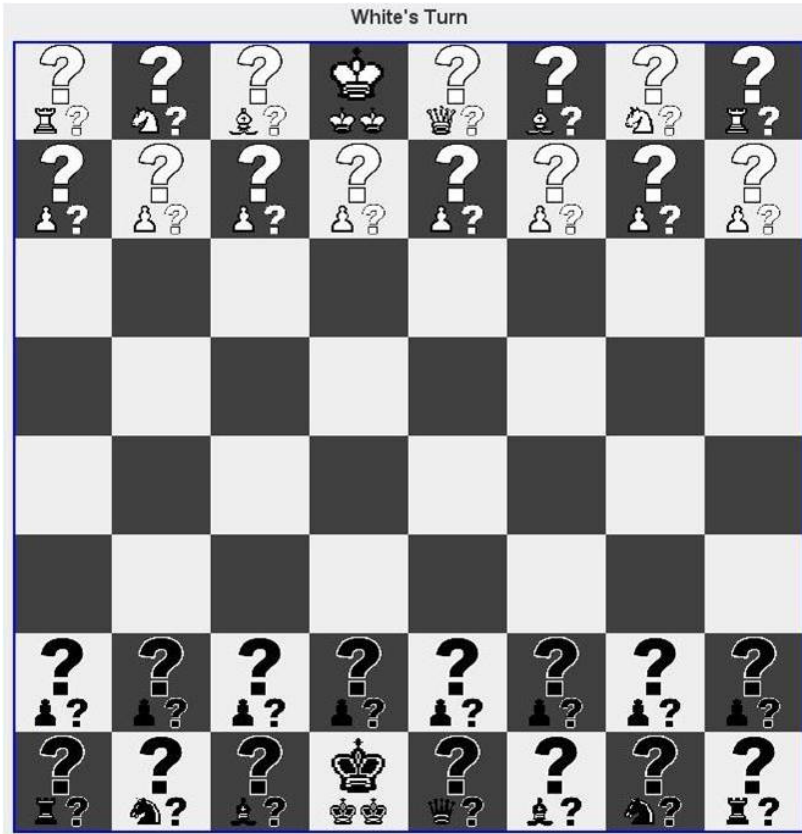

FIGURE 2
Quantum chess board at start of play

developed a strategy for the computer that involved tree search [6]. Figure 2 shows Alice's Quantum Chess board at the start of play.

5 AN INTERNET SENSATION

It was now time to test my hypothesis that Quantum Chess indeed restores the balance and evens the chances between humans and computers. A competition was held in the Queen's School of Computing on August 13, 2010 [7]. The human players varied from novice, to average, to expert. The computer had the upper hand against novice and average players. Interestingly, however, the expert players fared better, winning half of their games.

The media were invited to the competition and the Queen's Gazette ran a story on its web page [8]. Literally overnight, Alice was an Internet celebrity. Quantum Chess received coverage by the *CBC* (Canadian Broadcasting Corporation) and *Wired* magazine, among dozens of web sites, and a complimentary tip of the hat from the (then) reigning Women's World Chess Champion Alexandra Kosteniuk [9]. Most notably, Alice's work was featured on the NSERC (Natural Sciences and Engineering Research Council of Canada) web site [10].

6 MOVING FURTHER

For her undergraduate graduation project in 2011, Alice introduced some extensions to her first version of Quantum Chess. The new version, called Quantum Chess 2.0 [4], included the following additions:

1. Play could be set up so that either the black pieces or the white pieces may begin at the top of the board.
2. An option dialog displayed at the beginning of the program allowed the user to choose whether the game will be human vs. human or human vs. computer, and whether the human will be black or white (if human vs. computer), or which coloured pieces begin at the top (if human vs. human).
3. Castling was added to the game. However castling was not available to the computer AI, that is, human players may choose to castle when such an option is available, but the computer player will not be aware of the possibility of castling, either by itself or its opponent. Castling is illustrated in Figure 3.
4. Pawn capture *en passant* was also added. Again, while the choice was made to allow *en passant* capture as a valid move in the game, the computer player would not be aware of this option. *En passant* pawn capture is illustrated in Figure 4.

Alice also created a preliminary version of an entangled variation of Quantum Chess 2.0, which attempts to include the principle of quantum entanglement:

1. Both players' pieces have the same superposition combinations (the specific combinations are randomly assigned at game start up). Each piece therefore has a 'twin' piece of the opposite colour.

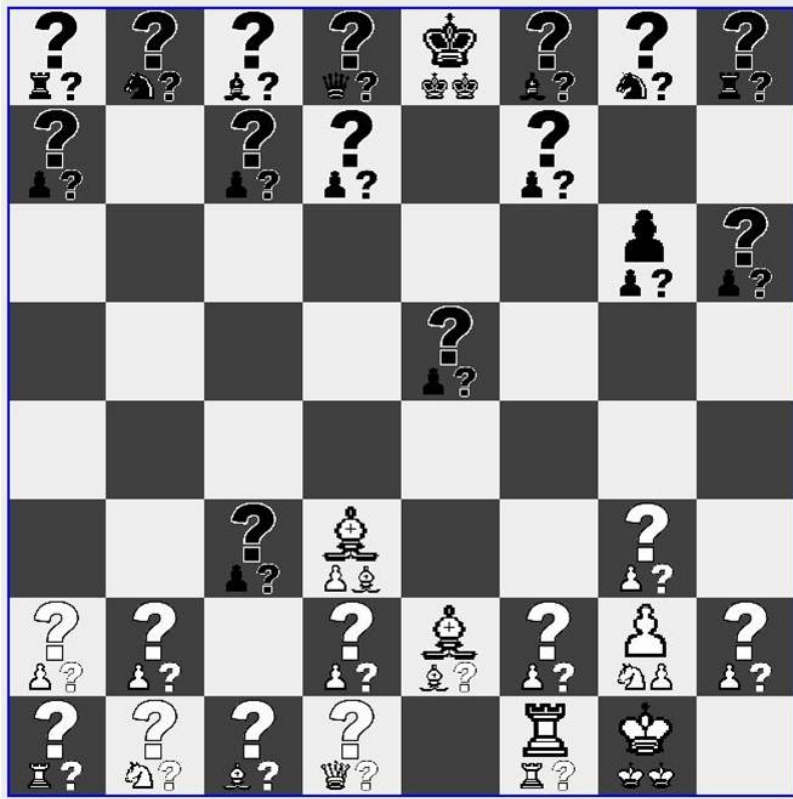

FIGURE 3
White has just castled.

2. All pieces, except for the king, start in quantum state, and both of their piece types are initially unknown. The location of the pieces within the player's first two rows is random. This is illustrated in Figure 5.
3. Each piece is initially entangled with its twin piece. When the piece is touched, its twin piece (belonging to the opponent) is also touched and collapses to the same state. Since both pieces are now in classical state, the entanglement is broken and the pieces behave normally henceforth.

The following improvements were left for future work:

1. Enhancing the computer strategy to take castling and *en passant* into account.
2. Creating a computer player for the entanglement version.

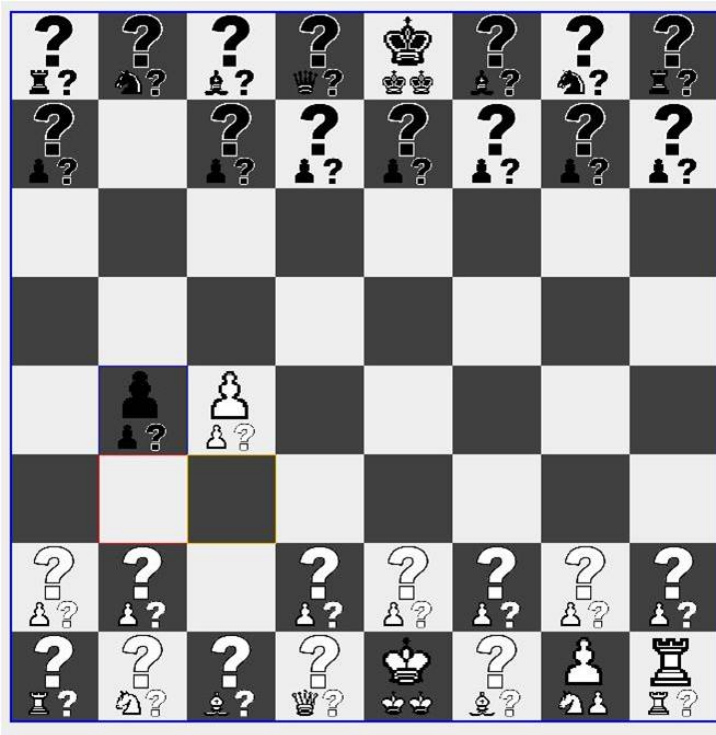

FIGURE 4
Black about to capture *en passant*.

3. Introducing the possibility of quantum pieces, when touched, collapsing with variable probabilities, to classical piece types.
4. Allowing for pieces to be superpositions of more than two piece types.

Alice graduated in 2011 and is currently pursuing a successful career as a computer scientist. In 2013, also for his undergraduate graduation project, another student, Brian Gudmundsson co-supervised by Professor Nick Graham, implemented Quantum Chess as a smart phone application [3]. This allows people in different locations to play the game against each other remotely.

7 HAWKING + HOLLYWOOD = HILARIOUS

After that, nothing much happened on the Quantum Chess front until three years later. On January 26, 2016, a movie was premiered at the California

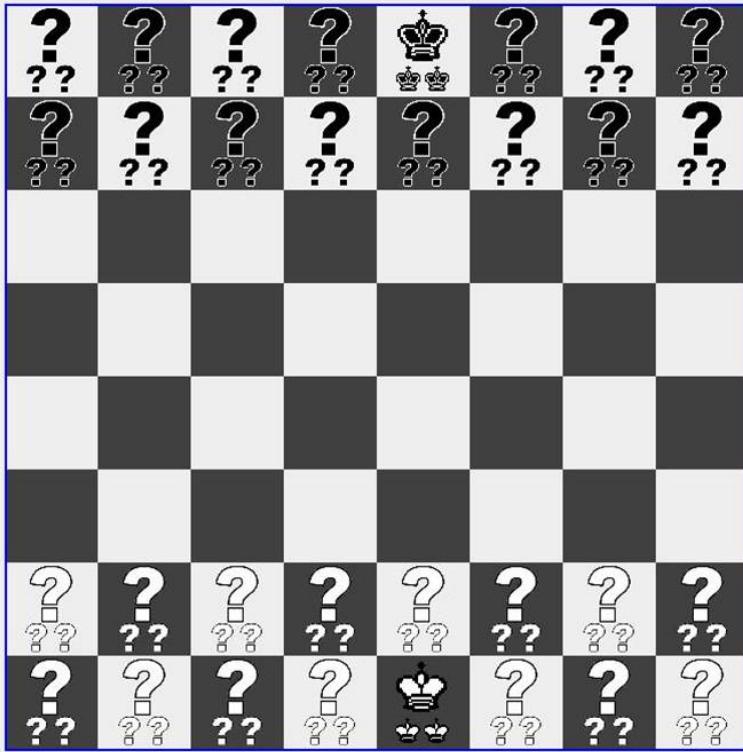

FIGURE 5
Entanglement version at start of game.

Institute of Technology during an event entitled *One Entangled Evening: A Celebration of Richard Feynman's Quantum Legacy* [11]. The movie captured a very funny game of Quantum Chess pitting Hollywood actor Paul Rudd against famous physicist Dr. Stephen Hawking [12]. The game they played is a variant of the original Quantum Chess [1, 2, 5, 6] in that quantum duality is of a different type: superposition is *spatial*, and represented by each chess piece being present on one of two different squares of the board with equal probability. This version, designed by Chris Cantwell, also allows pieces to be entangled [13]. Sadly, however, as these things go, the Internet quickly forgot [14, 15] the original inventors of Quantum Chess!

8 CONCLUSION

Games of strategy, and in particular chess, have long been considered as true tests of machine intelligence, namely, the ability of a computer to compete

against a human in an activity that requires reason. Today, however, most (if not all) human players do not stand a chance against the best computer chess programs. In an attempt to restore some equilibrium, I proposed Quantum Chess, a version of chess that includes an element of unpredictability, putting humans and computers on an equal footing when faced with the uncertainties of quantum physics. A software simulation of the game was implemented by an exceptional undergraduate student in 2010. It was extended in 2011 and then again in 2013. Experiments have shown that indeed Quantum Chess is an ‘equalizer’, as witnessed by the fact that humans indeed had a fighting chance against the computer. Even mediocre human players may be able to defeat superior ones, as demonstrated when a Hollywood actor and chess novice managed to defeat an illustrious scientist and chess expert in a version of the game inspired by Quantum Chess.

In conclusion, three observations are worth making in connection with the Quantum Chess phenomenon:

1. The true contribution to Quantum Chess is the original fundamental idea, namely, to show how the rules of quantum physics can be incorporated in the game of chess, in order to create a new game that is interesting and balanced.
2. Simulations of Quantum Chess on conventional computers are useful and fun, but they are not the real thing.
3. As noted in 2010, the real thing, that is, an authentic *Quantum Chess* board with authentic *Quantum Chess* pieces is still years away.

REFERENCES

- [1] Akl, S.G., On the Importance of Being Quantum, Technical Report 2010-568, School of Computing, Queen’s University, Kingston, Ontario, February 2010. <http://www.cs.queensu.ca/home/akl/techreports/quantumchessTR.pdf>
- [2] Akl, S.G., On the Importance of Being Quantum, *Parallel Processing Letters*, Special Issue on Advances in Quantum Computation, Qiu, K., Ed., Vol. 20, No. 3, September 2010, pp. 275–286.
- [3] Gudmundsson, B.R., Translating Java Applications to Android: Quantum Chess, CISC499 Final Report, School of Computing, Queen’s University, September 13, 2013.
- [4] Wismath, A., Quantum Chess 2.0, CISC499 Final Report, School of Computing, Queen’s University, April 8, 2011.
- [5] <http://research.cs.queensu.ca/Parallel/QuantumChess/QuantumChess.html>
- [6] <http://research.cs.queensu.ca/Parallel/QuantumChess/ChessApplet2/ChessGame.html>
- [7] <http://flux.cs.queensu.ca/news/2010/08/26/quantum-chess-competition/>
- [8] <http://www.queensu.ca/gazette/content/queens-school-computing-takes-quantum-leap>

- [9] http://www.cs.queensu.ca/home/aki/QUANTUM_CHESS/QuantumChessOnTheWeb.pdf
- [10] http://www.nserc-crsng.gc.ca/Media-Media/ImpactStory-ArticlesPercutant_eng.asp?ID=1053
- [11] <https://www.caltech.edu/content/one-entangled-evening-celebration-richard-feynmans-quantum-legacy>
- [12] <http://www.iflscience.com/physics/paul-rudd-challenges-stephen-hawking-game-quantum-chess>
- [13] <http://gizmodo.com/soon-we-can-all-join-paul-rudd-in-mastering-quantum-che-1756183601>
- [14] <http://nerdist.com/?s=quantum+chess>
- [15] <https://www.kickstarter.com/projects/507726696/quantum-chess>